

# ***PNEUMATIC CONVEYING***

## Operation & Maintenance Manual

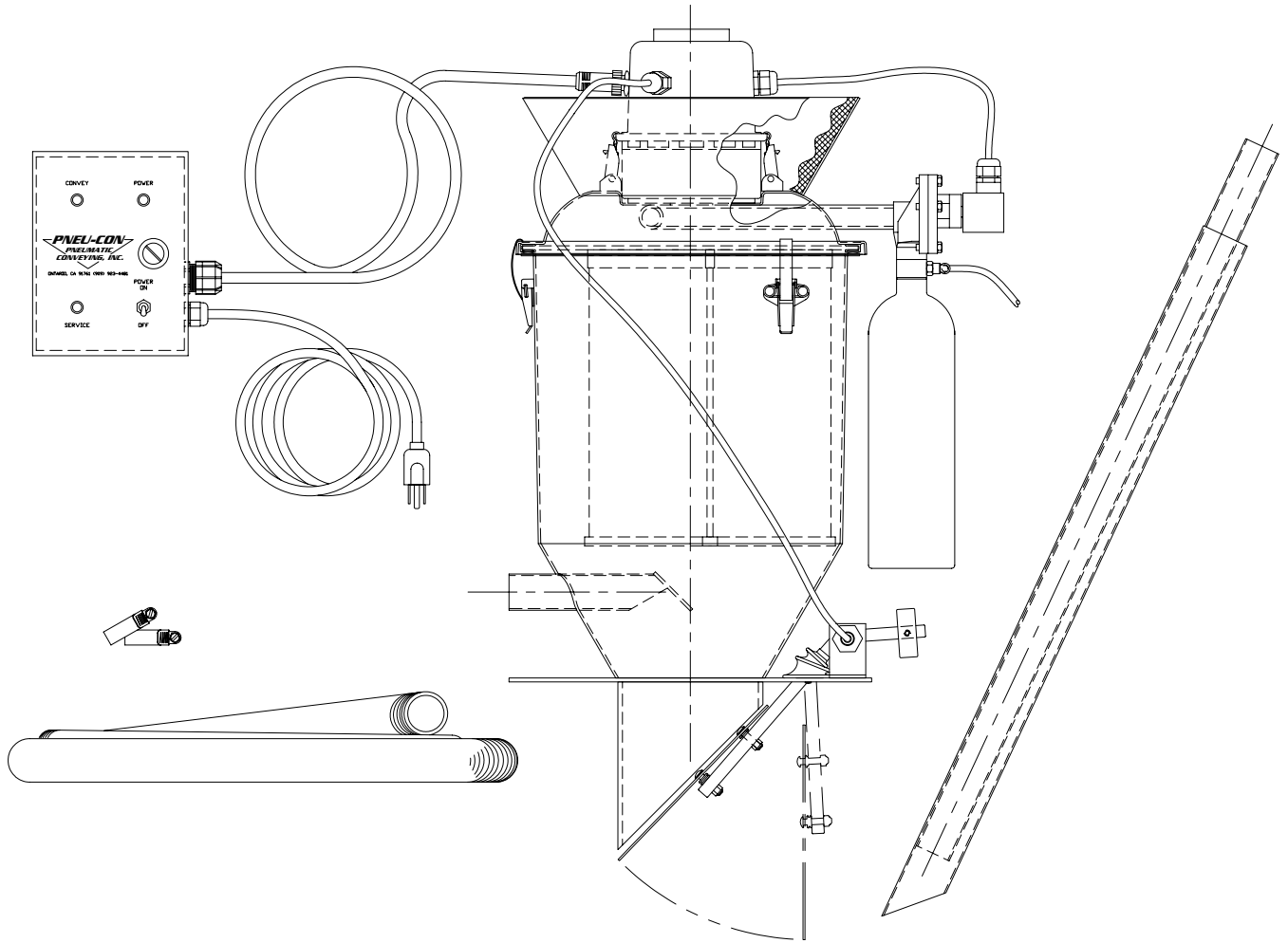

# ***Whisper® Loader™***



# ***Whisper® Loader™***

## Operation & Maintenance Manual

---

© 2007 Pneu-Con  
A Division of Pneumatic Conveying Inc  
960 E. Grevillea Court • Ontario, CA 91761  
Home Page: [www.pneu-con.com](http://www.pneu-con.com) • e-mail: [pneucon@pneu-con.com](mailto:pneucon@pneu-con.com)  
Phone 800.655.4481 • 909.923.4481 • Fax 909.923.4491

Manual P/N: 103249, Revised 11/2007

---

# Table of Contents

<b><u>INTRODUCTION</u></b>	<b>1</b>	<b><u>SEQUENCE OF OPERATION</u></b>	<b>15</b>
<b><u>SAFETY PRECAUTIONS</u></b>	<b>2</b>	<b><u>MAINTENANCE</u></b>	<b>16</b>
<b><u>UN-PACKING</u></b>	<b>3</b>	<b>MOTOR</b>	<b>16</b>
<b><u>SYSTEM DESCRIPTION</u></b>	<b>4</b>	MOTOR REPLACEMENT	16
<b><u>MODEL NUMBER DEFINITION</u></b>	<b>5</b>	MOTOR BRUSH REPLACEMENT	16
<b><u>COMPONENT, MODEL &amp; OPTION DESCRIPTIONS</u></b>	<b>6</b>	<b>FILTER MAINTENANCE</b>	<b>17</b>
<b>FEATURES AND BENEFITS</b>	<b>6</b>	FLAT FILTERS	17
<b>BASIC COMPONENTS</b>	<b>6</b>	CARTRIDGE FILTERS	18
<b>RECEIVING HOPPER</b>	<b>7</b>	<b><u>TROUBLESHOOTING</u></b>	<b>20</b>
<b>TANGENTIAL-ENTRY (TE) INLET OPTIONS</b>	<b>7</b>	<b><u>SPARE PARTS</u></b>	<b>21</b>
<b>WEAR-RESIST (WR) INLET OPTION</b>	<b>7</b>	<b>STANDARD KITS</b>	<b>21</b>
<b>VIBRA-PULSE™ (VP) OPTION</b>	<b>7</b>	LOADERS WITH PLC CONTROLLER & BRUSH-TYPE MOTOR	21
<b>PROPORTIONING-LOADER (PLVP) OPTION</b>	<b>7</b>	<b><u>NOTES</u></b>	<b>22</b>
<b>POWDER (PR) OPTION</b>	<b>8</b>	<b>SERIAL NUMBER LOG</b>	<b>22</b>
<b>MOTOR/TURBINE</b>	<b>8</b>	<b><u>ADDENDUMS</u></b>	<b>22</b>
240-VOLT MOTOR	8	<b><u>STANDARD CONDITIONS OF SALE</u></b>	<b>23</b>
EXPLOSION-PROOF MOTOR (XP) OPTION	9	<b><u>RETURNS</u></b>	<b>24</b>
BRUSHLESS MOTOR (BL2) OPTION	9		
<b>PROXIMITY SWITCH</b>	<b>9</b>		
<b>FILTRATION</b>	<b>9</b>		
POLYESTER/FELT FLAT-FILTER	9		
DI-AC MEDIA FLAT-FILTER	10		
PLEATED CARTRIDGE FILTER	10		
<b>GASKETS</b>	<b>10</b>		
FILTERS & TUBESHEETS	10		
MOTOR	10		
<b><u>CONTROLLER</u></b>	<b>11</b>		
<b>CONTROL PANEL</b>	<b>11</b>		
<b>PLC CONTROLLER</b>	<b>11</b>		
FACTORY SETTINGS	11		
QUICK-START	11		
<b>SERVICE INDICATOR</b>	<b>13</b>		
<b><u>MATERIAL PICK-UP</u></b>	<b>13</b>		
<b>PICK-UP LANCE</b>	<b>13</b>		
<b>HOSE</b>	<b>13</b>		
<b><u>INSTALLATION</u></b>	<b>14</b>		

---

## Introduction

*Thank you for choosing Pneu-Con for your vacuum-conveying system needs, we appreciate your business.*

**T**hrough years of reliable service and word-of-mouth praise leading to repeat business, Pneu-Con enjoys a customer base that has grown to reach all corners of the globe. For more than 30 years Pneumatic Conveying Incorporated has provided innovative, economical bulk material handling equipment and quality installations to its' customers. The core of Pneu-Con's quality products and services is the skill and expertise we focus on our clients' projects. Our professional staff represents over 175 years of experience in the bulk material handling processing industry offering a complete spectrum of bulk handling equipment, services and know-how. After-the-Sale satisfaction is important to us; therefore, we offer professional installation, start-up assistance, service and repair. Pneu-Con products are designed for simple, efficient and economical operation.



Pneu-Con's proven Self-contained Whisper® Loaders™ are complete ready-to-run Vacuum-Conveying Systems. We also provide custom-engineered Central-Powered Systems to meet and exceed your needs. Our staff of craftsmen (from fabricators, welders and machinists to field-service technicians) is available to mold your requirements into a complete, efficient and reliable system. Utilizing the latest in computer technology for drafting, engineering, inventory control, accounting and documentation, our customers receive prompt quality service. Engineering support is backed by a large database of conveying equipment resources including case studies, CAD drawings and custom engineering programs.

---

BEFORE YOU BEGIN

---

- ✓ Check All Packaging and Materials Upon Receipt of Equipment

---

  - 👤 Read All Instructions PRIOR to Operating this Equipment

---

  - ☎ Call our Factory for Support or Start-up Assistance

---

  - 📖 Review this Manual periodically to maintain full product awareness
- 

Pneu-Con maintains stock on a large inventory of standard products and replacement parts to support customer service. Whether replacement parts, components or a complete turn-key conveying system; let Pneu-Con handle your next project. Contact Pneu-Con's Sales Department, Customer Service or a local representative if you're interested in upgrades, system expansion or maintenance programs for your present system.

This OMM includes safety precautions, installation steps, maintenance procedures and supporting engineering drawings to assist both production supervisors and facilities maintenance engineers. Please take the necessary time to read this document in its entirety prior to operating the equipment.

A note to Plant Supervisors: Ensure that all personnel assigned to the operation and maintenance of this equipment has been fully trained. Periodically revisit this OMM to refresh & enforce your knowledge base of the equipment and its intended use.

## Safety Precautions

*This Manual uses the following words and/or symbols to indicate various ALERT levels.*

**DANGER** means that you are very likely to be killed or injured if you don't take the needed steps to avoid the hazard. This is the highest level of warning.

**WARNING** is for a situation where you could be killed or injured if you don't avoid the hazard.

**CAUTION** means you could receive moderate or minor injuries, or equipment could be damaged if you don't avoid the hazard.

The Control Panel and/or other system components may the following Warning Labels affixed.

WARNING

Material Handling and Processing machines could cause **DEATH, SHOCK, or INJURY.**

**LOCK OUT and TAG OUT** machine **POWER** before installing loader.

Follow safety steps in machine manual during installation process or whenever adjusting loader.

WARNING

**COMPRESSED AIR** could cause **DEATH, BLINDNESS** or **INJURY.**

Avoid contact. Compressed air can enter through skin pores, causing injury or death.

Do not direct compressed-air jet stream at any person.

Wear safety eyewear wherever a Compressed-air source is in use.

## Un-Packing

*The Whisper® Loader™ System is packaged in either a single carton or two cartons depending on physical size and/or carrier limitations.*

**CAUTION** The carton contents will be encapsulated with foam-filled poly bags, usually in clam-shell fashion. Do not damage or discard packing materials. Check carton contents ensuring that each and every component has been carefully removed. Some models have the Control Panel attached directly to the Loader's Mounting Flange, while most others will have a Remote Panel. For added protection, the Panel will be packaged in a "Jiffy" padded envelope. If separate, the Control Panel will be resting on top of the Loader.

There will be a length of Flex Hose coiled at bottom of carton along with Hose Clamps. Placed vertically in a corner will be a Pick-Up Lance, two Lances on certain models.

Do Not set Loader on its' Dump Valve/Flap as damage may result.

It is recommended that all packing materials be retained for at least the duration of the warranty period, typically one year, in case the unit should need service or repairs beyond the user's capacity or expertise. See RMA section at the back of this manual for details on obtaining a Return Authorization Number.

If, when you unpack the Whisper® Loader™ equipment damage is observed, notify the carrier immediately to file a damage claim. Most carrier claim policies allow a fifteen-day window for such claims; therefore time is of the essence.

## System Description

Pneu-Con *Whisper*® *Loader*™ packages are complete self-contained material-loading systems with an integral motor/fan (vacuum pump) providing efficient and economical operation with minimal maintenance and downtime. *Whisper*® *Loader*™ are shipped ready-to-run with minimal set-up. They are pre-wired to plug into a grounded 120VAC/Ø1/20Amp receptacle (240VAC/Ø1/60Hz optional) and designed to automatically convey material from a local source (typically located within 10 feet) up-and-over to a machine material hopper, extruder, 'Day' bin or similar type of receiving vessel.

Standard packages include: Vacuum-Loader, Aluminum Pick-up Lance (sized to match line size of the Loader's inlet), 10-ft length of clear PVC Flexible Hose (sized to match) with a pair of Hose Clamps and Control Panel. The *Whisper*® *Loader*™ is designed to automatically and efficiently maintain material levels in a receiving device, drawing material from the source – at a timed rate –set at the Control Panel. As an option *Whisper*® *Loader*™ can be supplied with a *Vibra-Pulse*™ filter-cleaning system to automatically clean the filter following each conveying cycle.

Pneu-Con *Whisper*® *Loader*™ operate on a batch principle. The duration of the conveying (run-time) and dump cycle (dump-time) is determined by the controller settings. The Control Panel is equipped with a PLC-type Controller module with adjustable (programmable) timer functions to control all timer-related Loader functions. Under special circumstances or for conveying distances greater than 10 feet, adjustments to the factory settings may be necessary. Refer to the PLC sections for further details.

The *Whisper*® *Loader*™ conveying-cycle frequency is "on demand" and will continue to cycle (convey material) whenever the level in the receiving vessel falls below the point of the Loader's Dump Valve Flap, thus allowing it to close. Once the Dump Valve swings open the Proximity Switch no longer senses the presence of the Valve's Arm and in-turn signals the controller to stop the Convey Cycle.

Numerous *Whisper*® *Loader*™ options are available beyond the Standard base model; from Filtration media (defined by the material being conveyed), receiving capacities, Proportional Conveying (from two material sources), Loader-construction (food-grade or other requirements). Standard *Whisper*® *Loader*™ have a PLC Control Panel which can be configured for various types of functions including auxiliary equipment controls.

Please Note: As of August 2006, due to ever-changing technologies and depleted resources, the PCB (board) controller has been phased-out of current production. Customers who wish to retro-fit existing 070 Control Panels to a new PLC controller – may contact Pneu-Con Sales Department or a local representative for details.

# Model Number Definition

The Model Number example below represents a typical *Whisper® Loader™* System and an array of options.

## **SC 1500 VP-TE-BL-SS-240-N4X**

Voltage & NEMA Rating:  
 120VAC NEMA 1 is Standard,  
 options are  
 240 – 240VAC/Ø1/60Hz  
 N12 – NEMA 12 Enclosure  
 N4X – NEMA 4X SS Enclosure

Material Contact Surfaces:  
 Aluminum is Standard, options are  
 SS – 304 Stainless Steel  
 CS – Carbon Steel  
 316 – 316L Stainless Steel

Motor/Fan Type (Vacuum Source):  
 Brush-type 120VAC is Standard, options are  
 BL2 – Brushless (Switched-Reluctance technology)  
           Second-generation BL  
 XP – Explosion-proof

Material Inlet Design:  
 Deflector Plate is Standard,  
 Optional Inlets include:  
 BT – Boxed Tangential Entry  
 FT – Full-Tangential Entry  
 TE – Semi-Tangential Entry  
 WR – Wear-resistant Entry

Filtration/Function:  
 No Vibra-Pulse™ is Standard, options are  
 VP – Vibra-Pulse™ (Automatic Filter-cleaning System)  
 PLVP – Proportioning Inlets (Two Inlets & Valves for rationed  
           material) with Vibra-Pulse™  
 PRXC – Powder (X = Filter quantity). 1 cartridge on SC1250  
           models, 3 cartridges on SC1500 – SC2000 models

Material Inlet Line Size:  
 1250 – Ø1-¼" OD  
 1500 – Ø1-½" OD  
 1750 – Ø1-¾" OD  
 2000 – Ø2" OD  
 Other sizes based upon  
 requirements available.

Basic Model Type:  
 SC – Self-Contained Whisper Loader Includes: Loader, Control  
 Panel, Material Pick-Up Lance with Flex Hose & Clamps and  
 Operator's Manual

# Component, Model & Option Descriptions

## FEATURES and BENEFITS

- Stand-alone Self-contained design Vacuum-Conveying System
- Spun & Welded Aluminum Body Construction – Standard
- Energy Efficient Solid State Controls operating on a Batch Principle
- Automatic Conveying for a wide range of materials and conditions
- Consistent loading of Machines, Hoppers or Day-Bins
- Take-apart design for Easy Cleaning & Maintenance

## BASIC COMPONENTS

The complete *Whisper® Loader™* Conveying System comprises the following major items (See Figure 1-1):

- ❑ Receiving Hopper Body with Inlet, Mounting Flange and Dump Valve Flapper Assembly with Proximity Switch (material level sensor)
- ❑ Flat-disc Nylon or Polyester-Felt media Membrane Filter (*Vibra-Pulse™* filter-cleaning system optional) and Gasket to seal Cover to Body
- ❑ Integrated Motor/Turbine, Brush-type standard (Brushless type option available)
- ❑ Control Panel housed in NEMA 1 Enclosure with ON/OFF Switch, Indicator Lights, Control Cord and Power Cord
- ❑ Material Pick-up Lance and PVC Flex Hose (quantity doubled for PLVP models)

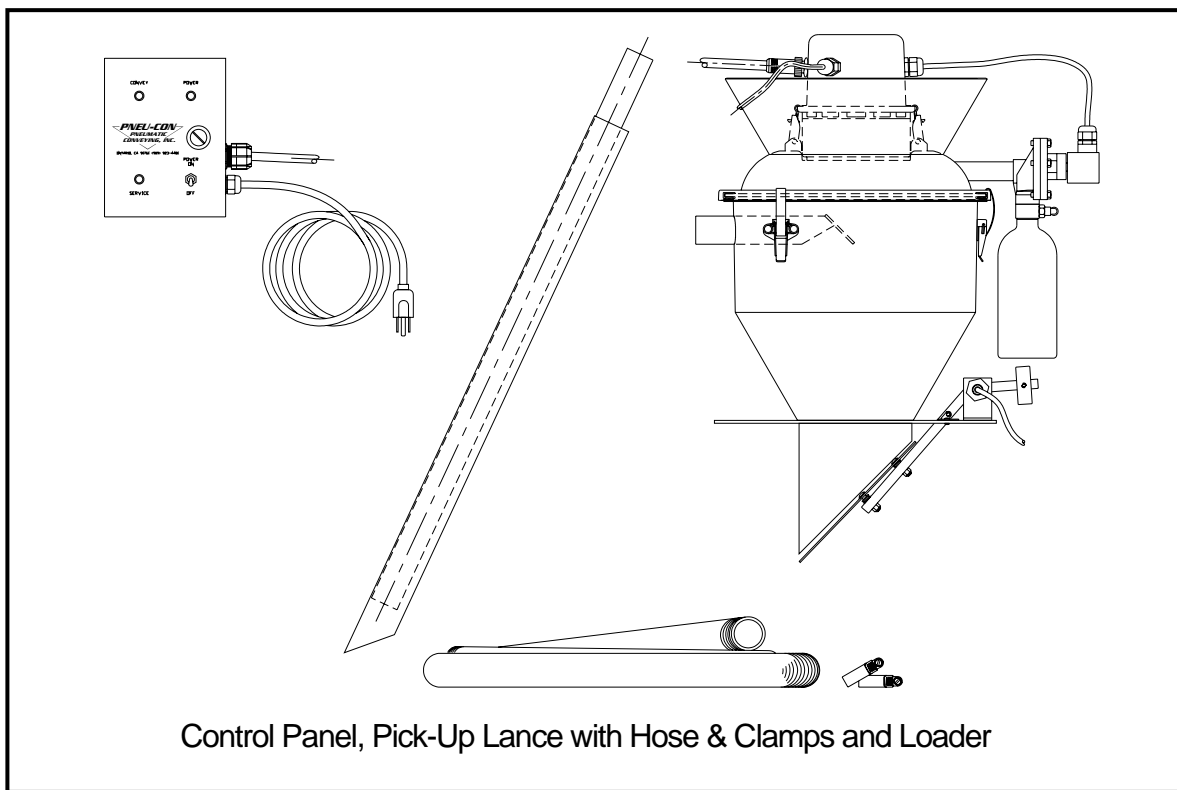

Figure 1-1 Major Components  
(Model SC1500VP Whisper® Loader™ shown)

## RECEIVING HOPPER

Constructed of spun-aluminum the Receiving Hopper Body includes a Discharge chute with Dump Valve and Mounting Flange. For material introduction an inlet (from Ø1-¼" thru Ø2" OD Tube Stub) is located on the side of the Loader's body. Proportioning (**PL**) models have two inlets (located side-by-side) permitting conveying multiple material types. As an option your Loader can be fitted with an Interblend® Static-blender as well as an optional Proximity Switch providing level-fill control at the **Virgin/Product 1** Inlet.

*Whisper® Loaders™* with Powder (**PR**) model designation require taller bodies to allow for Filter Cartridge(s) from 6" to 12" tall as standard (18" or 24" tall optional) and additional Body height as required to allow for required material-receiving capacity below extent of filter cartridge. **PR1C** models have a single filter, while the **PR3C** models are supplied with three cartridges, see following **PR** section for further details.

## TANGENTIAL-ENTRY (TE) INLET OPTIONS

The Tangential Entry series includes: Full (**FT**), Semi (**TE**), and Boxed (**BT**) Tangential Entries. The **FT** is a Full (flush to outside of Loader body) tangential-entry Inlet; the **TE** is a Semi tangential-entry Inlet is offset approximately ¾-distance from the center to the outside of the body; the **BT** is a round stubbed Inlet with a Full tangential-entry rectangular-design (boxed) transitioning connecting to the Body. Each Tangential Entry provides a degree of added protection for conveying delicate and fragile materials.

## WEAR-RESIST (WR) INLET OPTION

The Wear-Resistant (**WR**) Inlet is designed to protect the conveyed product from damaging the Loader's inlet or the conveyed material itself as it is introduced into the Loader. The terminal end of the Inlet is capped providing an area where product is retained within the Inlet to cushion incoming material, an opening along the bottom of the inlet tube allows material to fall into the Loader's receiver body. Also a special Replaceable version, sleeved and/or flange-mount design, can be incorporated into the **WR** Inlet.

## VIBRA-PULSE™ (VP) OPTION

The *Vibra-Pulse™* (**VP**) option to the Basic *Whisper® Loader™* is where the Loader's Cover Assembly is fitted with an automatic filter cleaning system:

Hardware: The **VP** System includes Loader Lid Assembly with integral Air Blast Pipes, Diaphragm Valve & Control Solenoid with Signal Cord, Air-Pulse Bottle and Air-supply Tubing (except 1250 models which have Pulse Valve and do not include Diaphragm Valve and Pulse Bottle assembly).

Function: At the end of each conveying cycle, the **VP** System will automatically clean the Filter(s) with a precision pulse of compressed air effectively loosening small particles and debris from the Filter's media.

## PROPORTIONING-LOADER (PLVP) OPTION

The Proportioning-Loader **PLVP** *Whisper® Loader™* is designed to automatically and efficiently convey material from two individual sources. **PLVP** Loaders are available with the *Vibra-Pulse™* (**VP**) system. The **Virgin/Product 1** source conveying line is connected to the Left-hand Inlet, **Regrind/Product 2** source connects to the Right-hand Inlet.

Hardware: **PLVP** *Whisper® Loaders™* are supplied with VP system (as shown above) two Pick-up Lances, a total of 20-ft of Flex Hose and (4) Hose Clamps (to accommodate both hose pieces). As an option the **PLVP** can be fitted with Interblend® (**IB**) Static-blender where the Loader's Receiver Body is divided into two compartments providing a rough mix of the ingredients prior to being discharged. The **IB** also reduces product layering within Loader.

Function: While the Loader is in the RUN mode, the Control signals **Ingredient 1** Valve to open drawing material from the **Virgin/Product 1** source for the allotted amount of time. At the elapse of T1 timer **Virgin/Product 1** Inlet Valve closes and **Regrind/Product 2** Inlet Valve opens to draw from **Regrind/Product 2** material source for duration of T2 timer. Total RUN time is culmination of both T1 & T2 timer functions. Simple Control Panel adjustments allow fine-tuning each timer.

## POWDER (PR) OPTION

Powder (PR) model series *Whisper® Loaders™* are designed to convey powders or other materials which produce a dusty bi-product. All PR Loaders are equipped with the VP System for automated filter cleaning. Series SC1250PR1C models are a single-cartridge design with a Ø8" ID X 16" side-wall Body with the material Inlet located just below Filter and supplied with (1) Filter mounted onto the Ø9" 1C Tubesheet. Loader models SC1500PR3C (Ø13" ID x 1" side-wall Bodies with Inlet on cone section) and SC1750PR3C & SC2000PR3C (Ø13" ID x 18" Bodies have Inlet on side-wall below Filter) are three-cartridge designs supplied with (3) Filters mounted onto Ø14" 3C Tubesheet. Additionally special body design options allow for more capacity and/or taller filters as well as a selection construction materials and finishes to suit various requirements.

## MOTOR/TURBINE

**DANGER** Please note that *Whisper® Loaders™* are powered by electric motors and must be installed and operated in an environment where contact with foam, liquid (including water) or other foreign substances does not occur. Do not allow these types of substances to enter the fan system, motor housing or other electrical components. When operating *Whisper® Loaders™* in potentially hazardous areas – environments containing dry chemicals or other volatile materials – an explosion-proof motor with special exhaust fittings must be utilized.

Failure to adhere to this precaution could lead to electrical shock resulting in flash fire (volatile substance exposure), equipment or property damage or personal injury or death. Review your application and/or installation with Pneu-Con prior to implementation.

The Vacuum Motor/Turbine assembly is a conventional 120VAC/60Hz/Ø1 Brush-type Motor coupled with a 2-Stage Turbine Fan. The Motor's Turbine produces two types of air movement: 1) Vacuum-conveying air which, after entering the Loader Body, is drawn up through the membrane Filter; and 2) Cooling/Discharge air. The Motor's cooling air is drawn through the openings in the top of the motor cover and discharged at the bottom periphery of the motor cover. Do not block air flow in and around the motor as damage may result. Typical life expectancy of the motor's brushes is approximately 400 operating hours. A SERVICE warning on the PLC appears when 400-operating hours has elapsed requiring Motor-Brushes to be changed; refer to the Maintenance section for details on replacing Brushes.

**WARNING** Failure to replace motor brushes in a timely manner may lead to irreparable motor damage, requiring motor replacement.

For special environment concerns *Whisper® Loaders™* can be fitted an Explosion-proof Motor to operate near flammable/explosive materials. In rare cases it may be necessary to utilize an inert-gas (Nitrogen) purge system to which Pneu-Con can provide a special motor with N<sub>2</sub> exhaust and recovery; also an optional closed-loop recover system is available. To meet these special circumstances Pneu-Con offers the following motor options:

### 240-Volt Motor

*Whisper® Loaders™* equipped with 240-Volt (240) Motors are designed for operation with 240VAC electrical mains supply source. **WARNING!** If the *Whisper® Loaders™* you purchased is equipped with

240VAC Motor and Controls **DO NOT** PLUG Control Panel cord into a power source other than 240VAC/60Hz/Ø1 or compatible voltage (i.e. 220VAC/50Hz/Ø1).

### Explosion-Proof Motor (XP) Option

The *Explosion-Proof Motor (XP)* option to the *Whisper® Loaders™* is required when hazardous conditions are present thus reducing the chance of accidental flash fires related to volatile materials or environment. The Loader is available with other options including NEMA 7/9 Control Solenoids.

*Whisper® Loaders™* equipped with Explosion-Proof (**XP**) Motors are designed for operation in hazardous environments; therefore it is imperative that all electrical connections are made utilizing suitably rated components for such. Proper grounding reduces/eliminates ignition sources caused by build up of static electricity that could discharge possibly igniting explosive or flammable vapors or volatile materials. Loader function & operation is the same as with Standard Motor-powered *Whisper® Loaders™*.

### Brushless Motor (BL2) Option

The *Brushless (BL2)* is our 2<sup>nd</sup> Generation Motor with integral 2-Stage Fan system controlled by Switched-reluctance technology. The **BL2** model option has no **SERVICE** warning requirement. The major advantage of the **BL2** is there are NO brushes on the commutator to wear out, eliminating the need to maintain motor brushes, resulting in fewer maintenance checks. Typical motor life is approximately 4000 hr minimum. As an option the motor can be configured with Variable-Speed (**VS**) Control circuitry to accommodate conveying delicate materials at slower speeds or dense, robust materials at the normal higher speed. The **BL2** is designed for use on Loaders having inlets Ø1-1/2" or greater.

Note: Because the **BL2** motor design requires a unique Loader-Cover with mounting tabs a direct retro-fit cannot be incorporated onto an existing Brush-type Motor Cover Assembly.

### PROXIMITY SWITCH

The frequency of material brought into the *Whisper® Loader™* is primarily controlled by the material level in the receiving hopper; when the vacuum is off the Dump Valve Flap is allowed to open. The Proximity Switch senses the Flapper's Pivot arm unless the Flap is held open by material in the receiving receiver. The convey cycle is on hold until the material level in the receiving receiver drops down low enough to permit the Dump Valve Flap to close restarting the cycle.

### FILTRATION

Proper filtration is crucial to the performance of your *Whisper® Loader™* and provides protection to the Motor/Turbine assembly. Filters are installed between the *Whisper® Loader's™* removable Lid Assembly and the Body's upper flange. *Whisper® Loaders™* have either of the following filter types installed: DI-AC (Diaphragm-Action), Poly-felt or Cartridge Filter (12" tall is standard, other cartridge lengths & filter media optional depending upon application). For most Pellet Loader applications the DI-AC filter is used. DI-AC Filters (Nylon media) are used for various applications (Standard models) and Polyester/Felt (PLVP & VP models) for dusty-material applications; while Cartridge-type Filters are used for powder-based materials.

### Polyester/Felt Flat-Filter

The **Poly-Felt** Filters are 16 oz Woven Light-Grey Polyester-Felt blend media Calendered (Heat-set) one side with particulate filtration of up to 0.05 micron. The **Poly-Felt** Filter is engineered for use in dusty applications where the conveyed material is dusty or expels a dust like bi-product. Maximum operating temperature 375° F. Note: Although the **Poly-Felt** filter captures much smaller particulate matter it does exhibit airflow characteristics slightly lower than a **DI-AC** filter.

## DI-AC Media Flat-Filter

Pneu-Con's **DI-AC** Filters are 1.12 oz Woven White Nylon monofilament providing excellent air-flow and filtration for particles as small as 55 micron.

## Pleated Cartridge Filter

Pneu-Con Pleated Filters are Ø5-1/2" x 6" or 12" long (Standard lengths) Closed-end Cartridges with a Spun-bond 225 Thread-count Non-woven White Polyester Pleated media exhibiting excellent air-flow and filtration for particles as small as 2-microns. Cartridges provide either 5.5-ft<sup>2</sup> (6" tall) or 11-ft<sup>2</sup> (12" tall) filter area. Each Cartridge has a Galvanized Steel Closed-End Bottom Cap & Open-ended Top Cap with two Mounting Studs and is supplied with a Mounting Gasket.

Options to our Standard Cartridges include, but are not limited to: PTFE-coated media, High-temperature rated media, Food-grade media and Stainless-steel End Caps as well as various Cartridge lengths to suit special cloth-to-air ratio applications providing up to 22-ft<sup>2</sup> filter area.

The Filter may be adequately cleaned with a vacuum cleaner, blast of air, or (in extreme cases) washed with a mild detergent and warm water. Please refer to the Filter Maintenance section of this Manual for further details.

**DO NOT SUBSTITUTE FILTER MEDIA WITHOUT DISCUSSING YOUR APPLICATION  
WITH A PNEU-CON APPLICATION ENGINEER OR CUSTOMER-SERVICE  
REPRESENTATIVE**

## GASKETS

### Filters & Tubesheets

**PLVP**, **VP** and **Standard** models utilize Flat disc-type Filters. Proper Membrane-type Filter installation incorporates a Gasket (e-shaped cross-section) placed around the periphery of Filter to make an air-tight seal between the Loader Body & Cover Assembly.

When re-installing Flat-Disc type Filters ensure the Filter's periphery is first installed in the slot of the Gasket with Filter seam-side facing up/smooth-side down (away from the motor). The Gasket orientation will be flat-side facing up/curved-side down (see diagram).

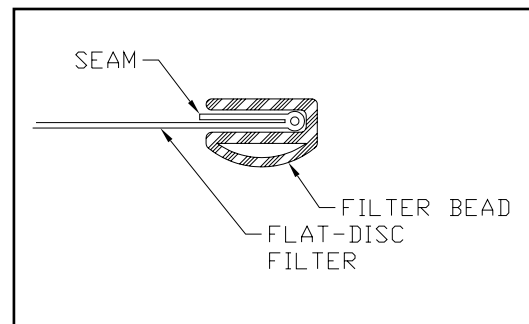

**PR** model loaders have cylindrical Pleated Filter Cartridge(s) installed. Each Cartridge is first mounted onto the Tubesheet using the Filter-mount Gasket provided. The Tubesheet will have a Body-to-Lid Gasket (e-shaped cross-section) installed on the perimeter of the Tubesheet prior to placing Filter/Tubesheet Assembly into the Loader's Body. The Loader's Lid can now be set in place and secured with the draw-type Latches.

When re-installing Cartridge-type Filters, mounted on a Tubesheet, the Tubesheet Gasket is installed with the flat-side facing up (towards the Motor – away from Loader Body).

Loader body size determines Cartridge quantity and is defined by the model number's suffix being either **PR1C** (one) or **PR3C** (three).

## Motor

Motor-mount Gasket is affixed to the top surface of the Lid. The Motor is then installed atop Gasket to seal. The Gasket ensures proper channeling of the Vacuum-conveying air up through Cover & Motor Assemblies.

# CONTROLLER

## CONTROL PANEL

The Control Panel's Enclosure (Fig. 2-1) includes a combination ON/OFF/Circuit-Breaker Switch, Status-Indicator Lights, Control Cord and Power Cord. Depending upon your particular Loader's functions, the Panel may have a different arrangement of Door-mounted controls and indicator lights than shown.

Control Panels on SC1250 & SC1250VP *Whisper® Loaders™* are mounted directly to the Loader's mounting flange. Control Panels on SC1250PLVP, SC1250PR1C & all other models are remotely-connected to the loader by the Control Cord. See Model-specific drawings (provided with this manual) for applicable wiring diagrams.

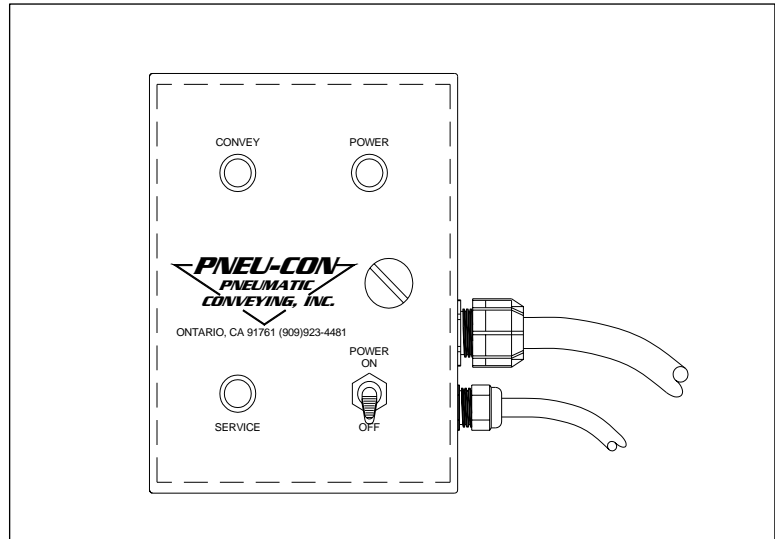

Figure 2-1 Control Panel Enclosure

The Control Panel is housed in a NEMA 1-rated enclosure with hinged access door and configured for 120VAC/Ø1/60Hz standard, 240VAC/Ø1 and other electrical power options are available. Use caution when plugging unit into receptacle – know your set-up beforehand.

## PLC CONTROLLER

### Factory Settings

Settings may be adjusted in the field to suit material conveying and/or operating conditions not covered in this manual. Consult factory to review special circumstances prior to making any changes.

### Quick-Start

Keypad Terminal: Initial Screen at Power-On will display System, Stop/Run or other Loader-function status. See Figure 2-2 for PLC Module's Keypad layout.

Pressing "Ok" brings up the Menu Selection Screen. Press the Center Pad "DOWN" Arrow until "Parameter" function is flashing. Press "Ok" to access the Timer-functions Screen.

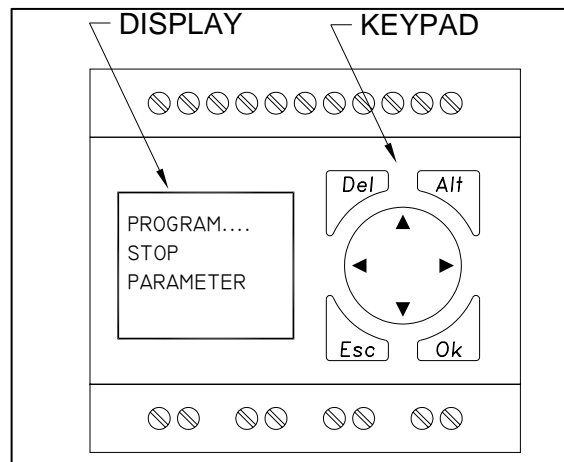

Figure 2-2 Module Keypad Layout

Press UP or DOWN Arrow until desired Timer is selected then press "Ok" for next screen. From here set time desired by pressing "Ok" while first-digit is flashing. Press Right Arrow (Center Pad) until the next digit to be changed flashes, and then UP or DOWN arrow until desired value is displayed. Repeat until entire time value is entered. Press "Ok" to save and then "Esc" to return to the previous menu. Press UP or DOWN arrow to access another Timer or "Esc" to save and return to previous menu.

Press "Esc" once again to return to the RUN Screen.

## Timer Descriptions & Functionality

**PR, VP & Standard (Basic) *Whisper® Loader™* Models:**

- T1: Run Time (Filling Duration)
- T2: (Not used)
- T3: Dump Time (Discharge Duration)
- T4: Pulse-Off Time (Duration between Pulses) for PR & VP (not used on Standard model)

**PLVP *Whisper® Loader™* Models:**

- T1: Proportioning Time (Filling Duration), Virgin/Product 1 Material
- T2: Proportioning Time (Filling Duration), Re grind/Product 2 Material
- T3: Dump Time (Discharge Duration)
- T4: Pulse-Off Time (Duration between Pulses)

### Optional Set-up:

On-Line/Off-Line Pulse Jumper Settings for the PLC Control Module to control the *Whisper® Loader's™* Vibra-Pulse™ Filter-Cleaning System. **PLVP & VP** Model *Whisper® Loaders™* are set for On-Line Pulse and **PR** models are set for Off-Line Pulse. For factory default jumper settings see Figure 2-3 diagrams below.

Caution: Refer to Wiring Diagram provided in your *Whisper® Loader™* Operating Manual as the applicable Input Contacts may vary from that shown below. The Wiring Diagram supplied with the Loader will identify the actual jumper location & related input terminal & wire numbers.

On-Line Pulsing occurs while the system is in the Conveying or Run Cycle (pulses the filters during the Conveying cycle), Off-Line Pulsing occurs while the system is in the Dump Cycle (pulses filters during the Dump cycle).

**DANGER!** Prior to performing ANY service or repairs **LOCK OUT** and **TAG OUT** electrical power & de-energize compressed-air sources.

To set On-Line Pulsing: Add **Jumper** wire from Wire #4 Terminal (L1 on the PLC Controller) to Wire #11 Terminal (I-4 on the PLC Controller).

To set Off-Line Pulsing: Add **Jumper** wire from Wire #4 Terminal (L1 on the PLC Controller) to Wire #9 Terminal (I-3 on the PLC Controller).

Note: There are no physical wires at either I-3 or I-4 terminals other than the **Jumper** wire; wires depicted are for illustration purposes only.

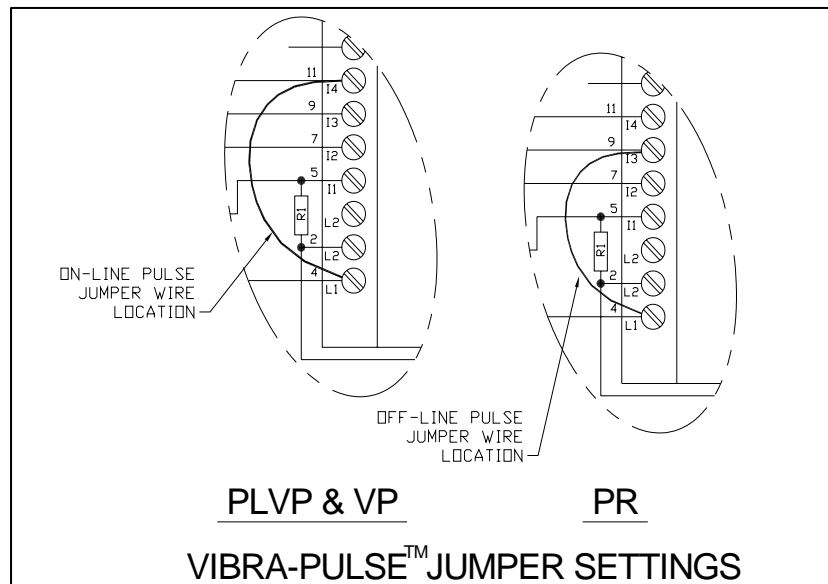

Figure 2-3 Jumper Settings

## CIRCUIT-BREAKER

To protect circuitry, the Control Panel ON/OFF Switch incorporates a Circuit Breaker providing overload protection. Should an overload condition arise the breaker trips putting the Switch's Baton in *neutral*. To reset breaker merely flip the switch to OFF, and then back to the ON position.

## SERVICE INDICATOR

This section refers to *Whisper® Loaders™* with Brush-type Motor. Pneu-Con recommends replacing the motor brushes after 400 hours of operation to prevent detrimental damage to the Motor. The Control Panel's internal timer device records accumulated hours of operation; at the 400-hour mark the **SERVICE** Alarm will illuminate – the Brushes must be changed. Once replaced the **SERVICE** Alarm must be reset by depressing the **UP** button on the PLC Keypad (see Figure 2-1 or 2-2).

**Note:** Failure to replace brushes in a timely manner will eventually damage the commutator requiring complete Motor/Turbine replacement. Please refer to Maintenance section for details on changing Brushes and other motor-related maintenance issues.

## Material Pick-Up

As standard a material Pick-Up Lance with Flex Hose are included with each *Whisper® Loader™* system. On Loaders with the **PL** option, two Pick-Up Lances plus an additional 10-ft length of Flex Hose (20-ft total) & two additional Clamps (4 total) are supplied to accommodate both material Inlets.

## PICK-UP LANCE

The Pick-up Lance is the material pick-up device which draws air down the crescent-shaped opening between the Outer Tube & Inner Probe (this area must remain open to air, DO NOT block or allow top-end to be inserted below material level) and then into source bin. There it will capture material and convey it up through the Lance's Inner Probe (inner probe sized to match line size of the loader inlet); then through the Flex Hose with final destination at the Loader Inlet. Pick-Up Lance options include; material of construction, adjustable take-apart sanitary designs, and Bag Guard protective End-pieces.

## HOSE

10-foot long PVC Flex Hose (inner diameter sized matches Loader's Inlet) with Integral Copper Ground Wire (to reduce/eliminate static built up). A pair of Stainless steel Worm-drive Hose Clamps is provided as standard. One end of the Flex Hose is attached to the Pick-up Lance's Inner Probe, the other end attached to the Loader's Inlet.

## Installation

Instructions for installing and setting up a Pneu-Con *Whisper® Loader™* Vacuum-Conveying System: *Whisper® Loaders™* should not be connected to extension cords as this may cause the circuit-breaker to trip due to voltage drop. Desired mounting surface (i.e. extruder, molding machine feed-screw inlet, hopper or day-bin) must be horizontal, flat (warp-free) and free from debris. Ensure surface is mechanically sound and able to rigidly support the *Whisper® Loader™*; bolt in place at the Mounting Flange. For your convenience a Flange mounting-template drawing is included. Pneu-Con offers an array of Hopper Covers to provide a custom fit on your material hoppers and other containers.

The receiving hopper should be vented to prevent pressurization. When properly mounted the Discharge Flapper (Dump Valve) MUST be slightly open with an approximate gap of 1/4" at the lower-most point (when system is not in vacuum mode). The counterweight on the Dump Valve pivot arm is factory adjusted and should require no further adjustment. Care should be taken to ensure the Dump Valve mechanism is working properly and able to swing freely to a full-open (flap vertical) position. Remedy any mechanical interference prior to placing *Whisper® Loader™* into service.

For Proximity Switch sensitivity adjustments and/or mounting instructions refer to applicable attachment(s) included with this manual.

On PLVP, PR & VP Model *Whisper® Loaders™* equipped with the *Vibra-Pulse™* (VP) system it is necessary to connect a dedicated, filtered, compressed-air supply line (see table for sizes) to the air INLET fitting on the VP Pulse Valve Body near Solenoid.

Loader Model	Line Size	Pressure Required
SC1250PLVP & VP Models (without Pulse Bottles)	3/8"	60-80psi
All other PLVP/PR & VP Model series (with Pulse Bottles)	1/4"	40-60psi

Next, make the material-conveying line connections by attaching one end of the provided Flex Hose to the Loader's Material Inlet and the other end to the Pick-up Lance's inner probe; secure using Hose Clamps provided. To reduce or eliminate static build-up within the conveying line and/or conveyed material attach the Flex Hose's integral Ground Wire to the Probe & Loader. Expose a short length of the wire at each hose-end, tuck inside of hose prior to connection. Routing of the Flex Hose should be as direct and straight as possible. Avoid tight-radius bends or kinking Flex Hose as this will impede flow resulting in sluggish system performance.

Now place the Pick-Up Lance into material source. Do not allow material level to be higher than the upper end of the Outer Tube as material will enter causing poor flow – even blockage.

For installations where the conveying distance is greater than 10 feet, longer hose lengths or rigid metallic tubing may be required. Pneu-Con recommends Aluminum tubing for its light-weight characteristics, ease of handling and inherent corrosion-resistant qualities. For conveying of abrasive materials carbon steel or stainless steel bends may be incorporated into the conveying line run.

Metallic tube bends/sweeps should have a centerline radius (twelve time tube outside diameter) on the material-conveying line. Material-conveying lines to be configured having predominately horizontal or vertical straight runs with a minimum number of bends to prevent "plugging" of the material. Please contact our Parts Department for assistance in selecting proper Bends, Sweeps and Couplings. Certain materials being conveyed may require conveying lines of either carbon steel for its ruggedness, or stainless steel to meet food-grade and/or clean room requirements. Compression-type Couplings with 3-Bolt or 4-Bolt Clamps are best suited for metallic-tube connections, please refer to Compression-Coupling section for additional information. Periodic inspection of the conveying line hose & tube, its condition and routing should be incorporated into the system's regular maintenance program.

## Sequence of Operation

The following is the sequence of operation for Self-contained Vacuum *Whisper® Loaders™*:

1. When the Control Panel Power Switch is in the **ON** position, the **POWER** light is on. If the Receiving Hopper is empty, the Dump Valve is allowed to close initiating signal to convey material, turning on the motor/turbine for the programmed amount of time (T1). While the motor is running, the **CONVEY** light is **ON**.
  - 1.1 **PL** *Whisper® Loaders™* have two ratio-controlled (proportioning) Material Inlets to draw from either of two sources: Virgin/Product 1 or Regrind/Product 2 material. Virgin/Product 1 proportioning valve will open to allow material to be conveyed (the Control Panel's Virgin/Product 1 indicator will be illuminated). After conveying the Virgin/Product 1 for prescribed time (T1), the Valve will close and then the Regrind/Product 2 Inlet valve will open allowing its' material to be conveyed (the Regrind/Product 2 indicator light is illuminated during this time). Once the total conveying time (T2) is achieved, the Loader will idle as described in Step 2.
2. The Loader will idle for the programmed **OFF** time (T3 - Off delay), allowing all material in the Loader to discharge into the receiving hopper.
3. For **VP** Loaders (**VP, PR & PLVP** models) the Motor idles in the **OFF** time mode, the Loader Control will automatically energize the **VP** Solenoid opening (T4 – Duration between Pulses) the Valve producing micro-blasts of air directed at the Filter(s) knocking particles safely away.
4. If the Dump Valve is held open by material in the receiving hopper, the Loader will continue idling until material falls low enough to allow the Dump Valve to close. The Proximity Switch senses the return of the pivot arm which in-turn signals the Control Panel.
5. After the signal, the Loader's RUN-Time starts producing vacuum and restarts sequence steps 1 thru 4. The Loader will cycle **ON** and **OFF** automatically to maintain level in the receiving hopper.

**NOTE:** Material density, moisture content and its flow characteristics (as well as other environmental factors) play a part in the system's overall conveying efficiency. Therefore, it may be necessary to make further adjustments outside of those mentioned in this manual. Make notations of these adjustments on the note page (contained herein) or in your maintenance records in case you need to reset factory settings. Incorporate these findings into a regularly scheduled maintenance/check routine.

## Maintenance

**DANGER!** Prior to performing any service or repairs **LOCK OUT** and **TAG OUT** electrical power and de-energize compressed-air source.

### MOTOR

Brush-type Vacuum Motors generally last a long time when properly maintained. Check Brushes regularly, replace at the accumulated operating time of 400 hours – the Control Panel indicator reminds the user of this important milestone. Replace worn or damaged Brushes immediately.

The optional Switched-Reluctance Brushless-type Motor of course does not need Brush service.

Proper break-in of new brushes required prior to applying full-load electrical current.

### Motor Replacement

1. **Disconnect Power Cord from receptacle.**
2. Remove electrical quick-disconnect Cords (Proximity Switch and Control) from the Motor Cover. These are threaded-body QD connectors. Rotate knurled Ring counter-clockwise to disconnect then unplug cord from receptacle.
3. Depress lock button to disengage each Latch holding the Motor-Cover onto the Motor.
4. Lift off Motor Cover to gain access to the Motor.

**CAUTION!** Exercise CAUTION performing steps 4a thru 4c. Rotate Motor Cover while lifting, avoid pulling on or otherwise damaging lead-wires, as they are permanently attached to the motor and are somewhat delicate. If these wires do get damaged beyond SAFE use, the entire motor needs to be replaced.

- a. Disconnect the wire-nuts connecting the Motor lead-wires to Control-Cord Receptacle (Connector for the large yellow-jacketed Cord).
  - b. Disconnect Motor ground wire.
  - c. Remove Motor (lead-wires intact).
5. Install NEW Motor and reconnect all wires, reversing steps above. Check condition of Motor-mount Gasket attached to Loader Cover, if necessary replace.
  6. Replace the Motor Cover, making sure the lead-wires are not damaged.
  7. Secure both Motor-Cover Latches (ensuring that a “click” is heard) locking them in place.
  8. Reconnect the Proximity Switch and Control QD (yellow-jacketed) Cords.
  9. Plug Loader’s Power Cord into receptacle.
  10. Press the UP button on the PLC board to reset the SERVICE Alarm (Loader must be connected to power source and Power switch turned ON to reset).

Your *Whisper® Loader™* is ready to be put back into service.

### Motor Brush Replacement

1. **Disconnect Power Cord from receptacle.**
2. Remove electrical quick-disconnect Cords (Proximity Switch and Control) from the Motor Cover. These are threaded-body QD connectors. Rotate knurled Ring counter-clockwise to disconnect then unplug Cord from Receptacle.
3. Depress lock button to disengage each Latch holding the Motor-Cover onto the Motor.

**CAUTION!** Exercise CAUTION when performing step 4. Rotate Motor Cover while lifting, avoid pulling on or otherwise damaging lead-wires, as they are permanently attached to the motor and are somewhat delicate. If these wires do get damaged beyond SAFE use, the entire motor needs to be replaced.

4. Lift off Motor Cover and set aside – leaving lead-wires attached – to gain access to Motor.
5. Carefully spread snap-on “Ears” of the plastic Fan Cover and remove to expose Motor Brushes.
6. Remove Brush-retaining Screws.

7. Place small-blade standard screwdriver between outer plastic Brush Housing and wire Slide Clips. Carefully pry outward with screwdriver – just enough to push Slide Clips closer to the Brush and slide it out from its locked position.
8. Insert NEW Brushes. Both Brush mechanisms must be replaced as a set.
9. Return Slide Clips to their locked positions to secure Brushes. Replace Brush-retaining Screws and plastic snap-on Fan Cover.

**WARNING! DIRECT APPLICATION OF FULL-RATED VOLTAGE TO UNSEATED BRUSHES WILL CAUSE ARCING & PITTING OF THE COMMUTATOR REDUCING MOTOR LIFE.**

10. To achieve optimum performance from your motor, new brushes should be seated on the commutator BEFORE applying full-rated voltages. Following Brush-set change apply 50% to 75% of rated voltage for thirty minutes to seat faces of Brushes on commutator. The motor will run achieve full-potential performance following thirty to forty-five minutes of operating at the full-rated voltage. Do not block off vacuum air inlet when running the motor.  
Alternately, if reduced voltage is not available for this step, two motors of like rating in series for the allotted time will provide the same results as above.
11. Follow any additional OEM instructions provided with the Brushes to obtain full brush life and peak motor performance.
12. Replace the Motor Cover, making sure the lead-wires are not damaged.
13. Secure both Motor-Cover Latches (ensuring that a “click” is heard) locking them in place.
14. Reconnect the Proximity Switch and Control QD (yellow-jacketed) Cords.
15. Plug Loader Power Cord into receptacle.
16. Press the UP button on the PLC board to reset the SERVICE Alarm. Press the UP button on the PLC board to reset the SERVICE Alarm (Loader must be connected to power source and Power switch turned ON to reset).

Your *Whisper® Loader™* is ready to be put back into service.

## **FILTER MAINTENANCE**

Filters are crucial to the *Whisper® Loader's™* performance AND provide protection to the Vacuum Motor/Fan Assembly. Check filters DAILY. Filters are cleanable, whether Flat-disc type or cylindrical Cartridge type. However, you MUST exercise care and follow the procedures outlined below. Should filter(s) require more-frequent manual cleaning please review your specific operating conditions with PCI Customer Service to achieve a reduction-in-maintenance solution.

**CAUTION** DO NOT use excessively-high air or water pressure. DO NOT use stiff-bristle brushes or similar devices. DO NOT otherwise scratch specially-treated filter surfaces. DO NOT use oils, solvents, harsh detergents or other abrasive cleaning agents & solvents. DO NOT apply direct (perpendicular to the pleated surface) air or water pressure on the dust side of the filter. **NEVER** point compressed-air nozzles directly at anyone! DO wear appropriate protective clothing for the contaminant you are cleaning and ensure any residue generated is properly contained and discarded per local environmental regulations.

### Flat Filters

#### CLEANING: DRY METHOD

Should DI-AC (Nylon) and Poly-Felt Flat Filters require cleaning, even beyond the capabilities of the Loader's *Vibra-Pulse™* system, remove and clean as follows:

1. Unlatch Lid, remove filter from *Whisper® Loader™*.
2. While holding filter at the perimeter Ring lightly tap (smooth side) against a firm surface to dislodge majority of larger particles.
3. Thoroughly vacuum; first from smooth side then seam side, so as not to embed particles further into media.

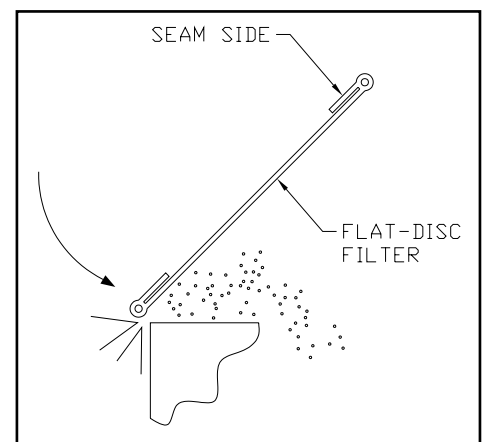

4. Repeat from smooth side to seam side until all visible debris has been removed.

#### CLEANING: WET METHOD

Additionally DI-AC filters can be cleaned using a mild detergent and air-dried.

1. Place filter in a 2%-3% (approximately 4 oz per gallon of water) solution of mild dish soap such as Ivory®, Joy® or Palmolive®. Allow to soak for about ten minutes.
2. With seam side facing you, wash filter. DO NOT scrub excessively as damage may result.
3. Remove from solution and rinse thoroughly, from the seam side straight through, under low-pressure stream of water. Rinse smooth side, and again from seam side until all soap residual is removed.
4. Allow filter to air dry completely, normally 24-48 hour period @ 70° F or lower. DO NOT dry filter inside of the Loader. DO NOT apply direct heat as damage will result.

#### Cartridge Filters

##### PTFE-Coated Cartridge

**WARNING!** If your *Whisper® Loader™* is fitted with special PTFE-coated Filter(s) use extreme caution during handling and cleaning of the cartridge(s). You are cleaning filter media surface-coated with a PTFE membrane (approximate thickness of 1 to 1-½ mills or about 1/8 the thickness of plumber's tape) laminated onto a non-woven, spun-bond substrate. DAILY Filter Inspection is required. Clean periodically as dictated by service load, replace when damaged or worn as surface abrasions and damage adversely affect filter performance. **DO NOT SCRUB.**

#### CLEANING: DRY METHOD

*Vibra-Pulse™* pre-clean Cartridge(s) Off-line (Vacuum Motor off) for approximately ten minutes with the Loader's **VP** system frequency setting at 15-second intervals at 100-milliseconds. The **VP** Valve shall remain connected to 60psig compressed-air source.

Should Pleated Cartridge Filters require further cleaning beyond that accomplished by the *Vibra-Pulse™* system, remove and clean as follows:

- Carefully lift out Tubesheet/Cartridge assembly from *Whisper® Loader™*.
- Loosen the Cartridge mounting hardware and remove Filter(s) from Tubesheet.
- The Tubesheet material-contact surface can be cleaned as required at this time. Dry thoroughly.
- While holding filter at the Upper (open) End Cap lightly tap (Bottom End Cap) against a firm surface to dislodge majority of larger particles, rotating as you work completely around filter.
- Lightly brush excess debris lodged within pleats in a sweeping motion as required starting from each end and working towards middle of filter. Turn filter over end-for-end and repeat.
- And/or vacuum, from dust side, using a soft-bristle brush so as not to embed particles further into media.
- Vacuum inside at closed End Cap to remove accumulated debris – if any.
- Apply a jet from compressed-air nozzle/wand held away from surface at 45° to filter's surface. **DO NOT** allow air device to scrape filter surface as damage may result. The air device opening must Ø3/8" or larger to prevent filter damage. Move nozzle along the full length of filter in a steady up & down motion.
- Using same technique in step 8, sweep inside of cartridge.
- Repeat steps 8 & 9 again to provide a clean sweep of both inside & outer surfaces.
- As an option, a vacuum nozzle can be used to clean the pleats as described in steps 8 & 9.

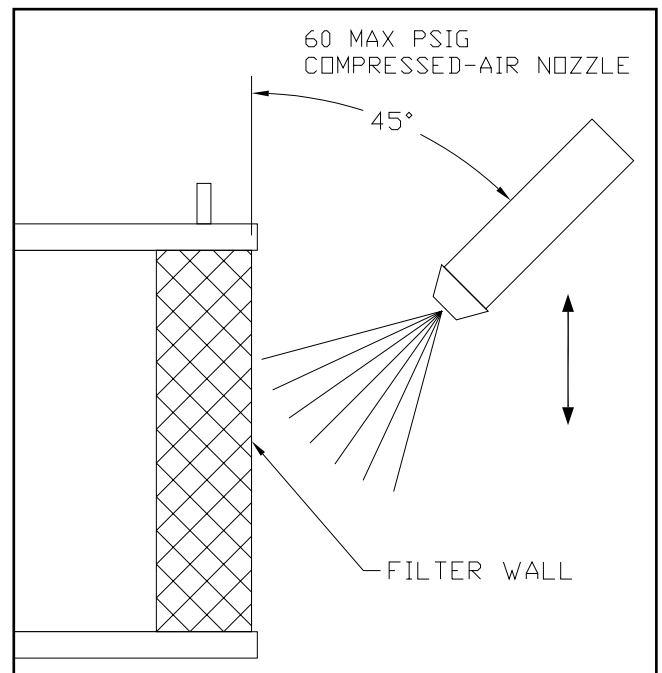
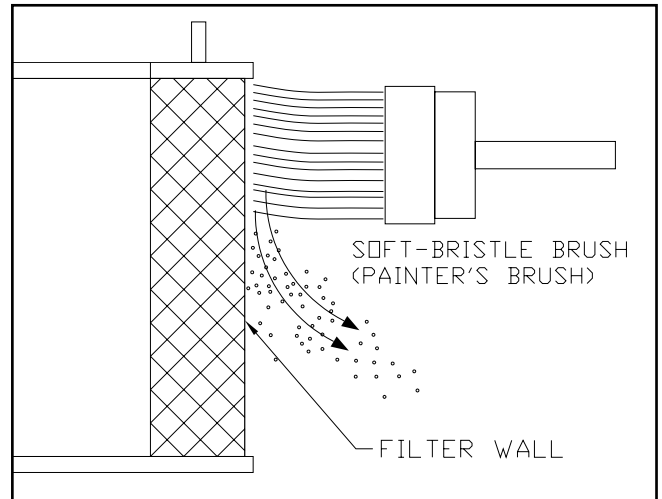

#### CLEANING: WET METHOD

Additionally Cartridge Filters can be cleaned using a mild detergent and air-dried.

- Pre-clean and brush Cartridge as described in Dry-Method above to remove excess dust particles.
- Place filter in a container with 2%-3% (approximately 4 oz per gallon of water) solution of mild dish soap such as Ivory®, Joy® or Palmolive®. Allow to soak for ten minutes.
- Remove from solution and flush with stream of clean low-pressure water. Hold hose end/nozzle away from and at 45° to filter surface. Water stream must not exceed 70 psig. **DO NOT SCRUB.**
- Rinse thoroughly, from the inside straight through to outside, under low-pressure stream of water. Rinse until all soap residual has been removed.
- Allow filter to air dry completely, normally 24-48 hour period @ 70° F or lower. **DO NOT** dry filter inside of the Loader. **DO NOT** apply direct heat as damage will result.

## Troubleshooting

The following situations may occur when installing or operating the *Whisper® Loader™*, please attempt to remedy the problem you have encountered prior to contacting Pneu-Con or its representatives for service. Exercise applicable safety precautions while working on electrical devices or compressed-air equipment.

**DANGER!** Prior to performing any service or repairs **LOCK OUT** and **TAG OUT** electrical power.

Problem	Probable Cause	Solution
Material is not being conveyed	<ol style="list-style-type: none"> <li>1. Filter blinded or plugged</li> <li>2. Conveying Line clogged</li> <li>3. Dump Valve not Sealing</li> </ol>	<ol style="list-style-type: none"> <li>1. Remove and Clean</li> <li>2. Clear line</li> <li>3. Check for bent Flapper or foreign-object obstruction</li> </ol>
No Virgin Material being conveyed	<ol style="list-style-type: none"> <li>1. Virgin Line Valve remains closed</li> <li>2. Control Knob is not turned to the full clockwise position</li> </ol>	<ol style="list-style-type: none"> <li>1. Check Valve's Air Cylinder and Solenoid</li> <li>2. Turn Control Knob CCW</li> </ol>
No Regrind Material being conveyed	<ol style="list-style-type: none"> <li>1. Regrind Line Valve remains closed</li> <li>2. Control Knob is not turned to the full counter-clockwise position</li> </ol>	<ol style="list-style-type: none"> <li>1. Check Valve's Air Cylinder and Solenoid</li> <li>2. Turn Control Knob CW</li> </ol>
Motor has high-pitched runaway sound during conveying cycle	<ol style="list-style-type: none"> <li>1. Loader Receiving Hopper Body full</li> </ol>	<ol style="list-style-type: none"> <li>1. Shorten Motor <b>ON</b> time</li> </ol>
Motor continues to cycle after receiving hopper is full	<ol style="list-style-type: none"> <li>1. Proximity Switch being activated</li> </ol>	<ol style="list-style-type: none"> <li>1. Check that Dump Valve Pivot Arm is NOT sensed by Proximity Switch, make necessary adjustments</li> <li>2. Faulty Proximity Switch</li> </ol>
Motor does not run	<ol style="list-style-type: none"> <li>1. No 120 Volt supply</li> <li>2. Breaker tripped</li> <li>3. Motor Brushes improperly installed or worn out</li> </ol>	<ol style="list-style-type: none"> <li>1. Remedy as required</li> <li>2. Reset Breaker</li> <li>3. Re-install Brushes, perform brush-seating procedure or replace Brushes</li> </ol>
Power light does not operate	<ol style="list-style-type: none"> <li>1. No 120 volt supply available</li> <li>2. Tripped circuit breaker</li> </ol>	<ol style="list-style-type: none"> <li>1. Check for power at outlet</li> <li>2. Reset or check Breaker</li> </ol>
Circuit-Breaker Switch fault	<ol style="list-style-type: none"> <li>1. Pinched or chaffed wires</li> <li>2. Incorrectly-sized Breaker</li> </ol>	<ol style="list-style-type: none"> <li>1. Check under Motor Cover and inside Enclosure for pinched or damaged wires</li> <li>2. Install correctly-sized Breaker</li> </ol>
Filter (Flat Disc or Cartridge type) quickly becomes clogged or dirty	<ol style="list-style-type: none"> <li>1. No air supply available (keeping Vibra-Pulse™ from performing)</li> <li>2. Air pressure too low (keeping Vibra-Pulse™ from working correctly)</li> <li>3. Pulse cycle setting too low, not enough pulses during OFF time</li> <li>4. Pulse time duration set longer than Dump time</li> <li>5. Jumper (Off-line or On-line) not placed correctly or missing.</li> </ol>	<ol style="list-style-type: none"> <li>1. Check for broken or loose airline fittings</li> <li>2. Increase air supply pressure – <b>Do Not exceed 100psi</b></li> <li>3. Decrease cycle lengths for more pulses during OFF time</li> <li>4. Decrease Pulse time</li> <li>5. Check that Jumper wire present and connected properly (see Fig. 2-3)</li> </ol>

## Spare Parts

To ensure minimum down time during routine maintenance Pneu-Con recommends that a spare parts kit (see tables below) be kept in stock. A typical Spare Parts Kit (**SPK**) contains essential consumable items such as Filters, Gaskets and Motor Brushes (for Standard Brush-type Motor only).

Also, many of the Loader's parts beyond those included in the **SPK** may be kept on hand as well. All Loader parts can be ordered individually, see applicable *Whisper® Loader™* assembly drawing for specific part numbers. For pricing and availability contact PCI Parts Department.

### STANDARD KITS

#### Loaders with PLC Controller & Brush-type Motor

SC1250PLVP, SC1500PLVP, SC1750PLVP & SC2000PLVP model **SPK** contain the following items:

- 2 pc Flat-Disc Filters, Poly-Felt Standard; Ø9" (SC1250), Ø14" (SC1500 – SC2000)
- 1 pc Rubber Gasket, Black Standard; Ø9" (SC1250), Ø14" (SC1500 – SC2000)
- 2 set Motor Brushes, 120VAC Motor Standard; SC1250/SC1500 or SC1750/SC2000

SC1250PR1C, SC1500PR3C, SC1750PR3C & SC2000PR3C model **SPK** contain the following items:

- A/R pc Cartridge Filter(s), 12" tall Standard; 1 pc (SC1250), 3 pc (SC1500 – SC2000)
- 1 pc Rubber Gasket, Black Standard; Ø9" (SC1250), Ø14" (SC1500 – SC2000)
- 2 set Motor Brushes, 120VAC Motor Standard; SC1250/SC1500 or SC1750/SC2000

SC1250, SC1500, SC1750 & SC2000 model **SPK** contain the following items:

- 2 pc Flat-Disc Filters, DI-AC Standard; Ø9" (SC1250), Ø14" (SC1500 – SC2000)
- 1 pc Rubber Gasket, Black Standard; Ø9" (SC1250), Ø14" (SC1500 – SC2000)
- 2 set Motor Brushes, 120VAC Motor Standard; SC1250/SC1500 or SC1750/SC2000

SC1250VP, SC1500VP, SC1750VP & SC2000VP model **SPK** contain the following items:

- 2 pc Flat-Disc Filters, Poly-Felt Standard; Ø9" (SC1250), Ø14" (SC1500 – SC2000)
- 1 pc Rubber Gasket, Black Standard; Ø9" (SC1250), Ø14" (SC1500 – SC2000)
- 2 set Motor Brushes, 120VAC Motor Standard; SC1250/SC1500 or SC1750/SC2000

Note: *Whisper® Loader™* models with the **BL** Motor option do not include Brush Sets.





## STANDARD CONDITIONS OF SALE

1. PNEU-CON, DIVISION OF PCI, (henceforth referred to as PCI) guarantees that its products are free from defects in materials and workmanship, and that if, within one year from date of shipment thereof, any guaranteed products should fail for the foregoing reasons, PCI will replace or repair such product free of charge under conditions described herein.

PCI does not guarantee the performance of any product except as may be expressly stated to the contrary in the applicable quotation or other documents of which these conditions are a part.

Guarantees of products not manufactured by PCI, including purchased components, shall be limited to the guarantees and warranties of the respective manufacturers.

THE WARRANTIES, OBLIGATIONS AND LIABILITIES OF PCI SET FORTH HEREIN ARE EXCLUSIVE AND IN SUBSTITUTION FOR ALL OTHER WARRANTIES, OBLIGATIONS AND LIABILITIES OF PCI, EXPRESSED OR IMPLIED, INCLUDING THE IMPLIED WARRANTY OF FITNESS FOR A PARTICULAR PURPOSE WITH RESPECT TO ANY NON-CONFORMANCE OR DEFECT IN PRODUCT. IN NO EVENT SHALL PCI BE LIABLE TO BUYER OR ITS CUSTOMERS FOR LOSS OF USE, REVENUE OR PROFIT, OR FOR ANY OTHER INCIDENTAL OR CONSEQUENTIAL DAMAGES ARISING OUT OF OR RELATING TO THE TRANSACTIONS HEREIN.

2. ALL CLAIMS under the guarantee above must be made promptly in writing to PCI. Defective material must either be returned to PCI, freight prepaid, or made available for inspection at customer's location within thirty (30) days of written claim.

3. RETURNS - Before returning any material, CUSTOMER will request a Returned Material Authorization (RMA) number from PCI and this number must be used to identify the returned material and all associated documents. ALL RETURNED MATERIAL MUST BE SHIPPED PRE-PAID.

4. Any replacement parts will be shipped freight collect. Shipment of replacements prior to receipt and inspection of presumed defective parts does not waive the rights of PCI. The decisions to repair, replace, or issue credit for defective material rests solely with PCI.

5. PRICES - All prices are F.O.B. PCI dock, Ontario, California, or point of manufacture. Prices do not include sales, use, excise, or similar taxes, which shall be paid by the PURCHASER or in lieu thereof, the PURCHASER, shall provide PCI with a certificate of tax exemption acceptable to the taxing authorities.

6. ORDERS - Are binding and valid, all orders must be accepted in writing by the COMPANY at its principal office in Ontario, California. PCI reserves the right to refuse any order prior to its written acceptance.

7. DELIVERY - Delivery dates refer to the dates when it is estimated that the equipment will be ready for shipment from the place of manufacture and are based on prompt receipt by the seller of the order and of information without interruption. It is understood and agreed that shipping dates are approximate only and while PCI will use all reasonable diligence to meet them, it does not guarantee any shipping date.

8. DELAYS - If shipment is delayed at PURCHASER'S request, payments due upon and after shipment is due as though shipment has been made at the time CUSTOMER was notified that shipment was ready.

If shipment is delayed more than seven (7) days at CUSTOMER'S request, material may be stored at PCI premises or a public warehouse; and CUSTOMER agrees to pay all reasonable storage and removal charges related to such storage.

9. PAYMENT TERMS - Unless otherwise specified all payments are null and void, and shall be deemed deleted from this agreement, and all remaining terms of the agreement shall remain in full force and effect, due within thirty (30) days of the invoice date. Invoices not paid within this time period are subject to an interest charge of one-and-one-half percent (1-1/2%) per month (18% annually) on the unpaid balance. BUYER agrees to pay to SELLER all costs and reasonable attorney fees for collection of delinquent accounts.

10. ENGINEERING CHANGES - PCI reserves the right to make changes in designs and/or construction in its products at any time without incurring any obligation on units previously delivered to modify such units to include subsequent changes.

11. TERMINATION - Upon written notice to PCI PURCHASER may terminate the contract of which these conditions are a part. For standard products the PURCHASER shall incur a cancellation fee of twenty percent (20%) of the selling price of such equipment.

For special products not part of PCI's standard product line, PCI shall cease work and deliver to PURCHASER all completed or partially completed equipment and work in process. PURCHASER shall pay PCI the contract price for all completed equipment, plus all expenses borne by, or on behalf of, PCI in connection with partially completed work including direct factory and engineering costs, cancellation charges to PCI on account of any commitments made under the contract, and an additional 10% of all charges to cover overhead.

12. PURCHASER - will use and shall require its employees to use all safety device and guards on the shipment and maintain the same in proper working order. PURCHASER shall use and require its employees to use safe operating procedures in operating the equipment. If PURCHASER fails to observe the obligations in this paragraph, PURCHASER agrees to indemnify and save PCI harmless from any liability or obligation incurred by PCI to persons injured directly or indirectly in connection with the operation of the equipment. PURCHASER further agrees to notify PCI promptly and in any event within thirty (30) days, of any personal injury or damage to property and to cooperate fully with PCI in investigating and determining the causes of such accident or malfunction. In the event that PURCHASER fails to give such notice to PCI or to cooperate with PCI, PURCHASER agrees to indemnify and save PCI harmless from any claims arising from such accident or malfunction.

### 13. CONTRACTS INVOLVING FIELD ERECTION

A) PURCHASER'S cancellation of this contract during or after erection of equipment (associated with this contract) performed by field subcontractors is subject to payment for all actual costs; including materials ordered, subcontractors issued, materials delivered and any other cost reasonably incurred as a result of the cancellation, plus the value of the work completed based on the percentage of completion of the value of erection as determined from the breakdown on the contract value established for billing purposes plus ten percent (10%) of the contract price.

B) Prior to field mobilization for erection, Purchaser may be able to delay commencement of erection for a period up to 12 months provided that a mutually acceptable adjustment to the contract price is negotiated, including overhead and profit thereon, as a result of said delay. In addition, VENDOR shall be entitled to an extension of the contract time equal to the extent of the delay or any consequence thereof.

C) If Prior to field mobilization for erection, PURCHASER delays the commencement of erection beyond 12 months; VENDOR has the option of canceling the contract and being reimbursed pursuant to Paragraph A above. If VENDOR does not exercise its' right to cancel then the parties will negotiate an equitable adjustment to the contract price plus an extension of time to complete the contract.

### 14. GENERAL:

A) This agreement is the final and complete agreement of the parties. There are no other agreements, contracts, understandings, or representations, oral or written, expressed or implied with respect to this transaction or the equipment being sold hereunder. No amendment thereto shall be effective unless in writing and signed by the parties.

B) In all cases clerical errors are subject to correction.

C) In the event that any terms of this agreement be or become or are declared to be invalid or void by any court of competent jurisdiction such terms shall be

D) The validity, enforceability and interpretation of the above terms and conditions shall be determined and governed by the laws of the state of California.

## Returns

Should your Loader or any of its components require service or replacement, contact the factory for a Return Material Authorization (**RMA**) number prior to returning items. A return should only be executed after exhausting all possible remedies outlined in the Troubleshooting section, or attempts to remedy as instructed by customer service technical staff.

Prior to contacting PCI have the unit's model number and serial number (located on the Loader's mounting flange) and any other information relating to the specific order available when calling. For proper receiving and tracking, please ensure that all accompanying paperwork references your assigned RMA number.

Thank you for choosing Pneu-Con Inc. for your material handling needs, if you should have any further questions as to the operation of this unit or any other PCI product please contact Customer Service at (909) 923-4481 or (800) 655-4481, Monday thru Friday between the hours of 8:00 AM and 4:30 PM Pacific Time.



